

# Tube decoration

Individual printing solutions for plastic tubes and sleeves





# New perspectives for your finishing portfolio

DiF <sup>1)</sup>      Screen Printing  
Digital printing      Hybrid      Efficiency  
    **Inline**  
Flexibility      Flexo printing  
    **Stand-alone**      Design  
IDD <sup>2)</sup>      inLINE FOILING®

<sup>1)</sup> Digital inLINE FOILING®  
<sup>2)</sup> Indirect Digital Printing

*“At first glance, tubes look quite simple. But they are versatile in use and complex in finishing. This contrast is what motivates us to find solutions that allow the added value of tubes to become visible in a brilliant and efficient way.”*

**Torsten Hirschnitz,**  
CEO ISIMAT GmbH Siebdruckmaschinen



## First choice for efficient and extraordinary tube decoration

Plastic tubes may seem simple in appearance. But behind their simple form lies enormous versatility. As flexible and cost-effective all-rounders among product packaging, they are highly valued by manufacturers and consumers alike – as an efficient type of package for pastes and viscous fluids, for their practical application, and for their sales-promoting effect. In order to fully exploit their value functionally and emotionally and to impressively present unique brand messages, it is important to understand the complexity of the tube and at the same time translate it into individual and comprehensive decoration solutions – such as those from ISIMAT.

As an expert in complex, fully automated, high-performance printing machines, ISIMAT is the number one choice for tube decoration and your first choice for efficiency, quality, and exceptional finishing of sophisticated hollow bodies and tubes. Benefit from tailor-made solutions ranging from stand-alone tube printing machines to integration into existing production lines that fully meet your individual requirements for cost-effective processing, first-class finishing, and new design options for your tubes.

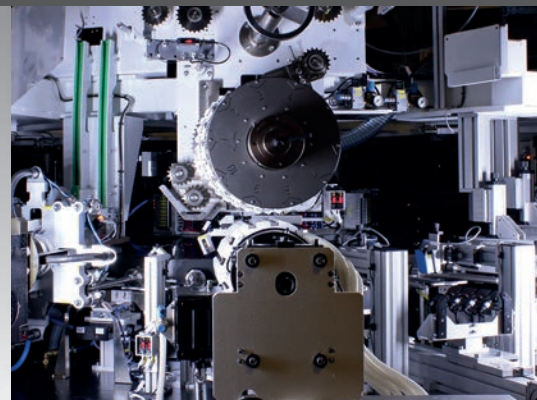
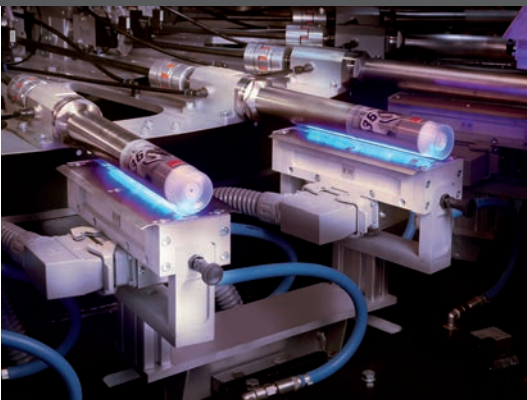

We offer the technology.  
The choice is yours.

Your choice for  
**razor-sharp text**



Screen Printing

Your choice for  
**photo-realistic images**



Flexo printing

Keen to impress your customers with first-class decoration of tubes and sleeves – always right on point in terms of quality, time, and budget? With our solutions we offer you exactly what you need to fulfill your customer requirements: a complete range of printing technologies from proven screen and flexo printing through innovative inLINE FOILING® to highly flexible digital printing.

Your choice for  
**brilliant metallization**



inLINE FOILING® / DiF

Your choice for  
**custom special editions**



IDD



Sophisticated technology  
for every conceivable  
decoration requirement

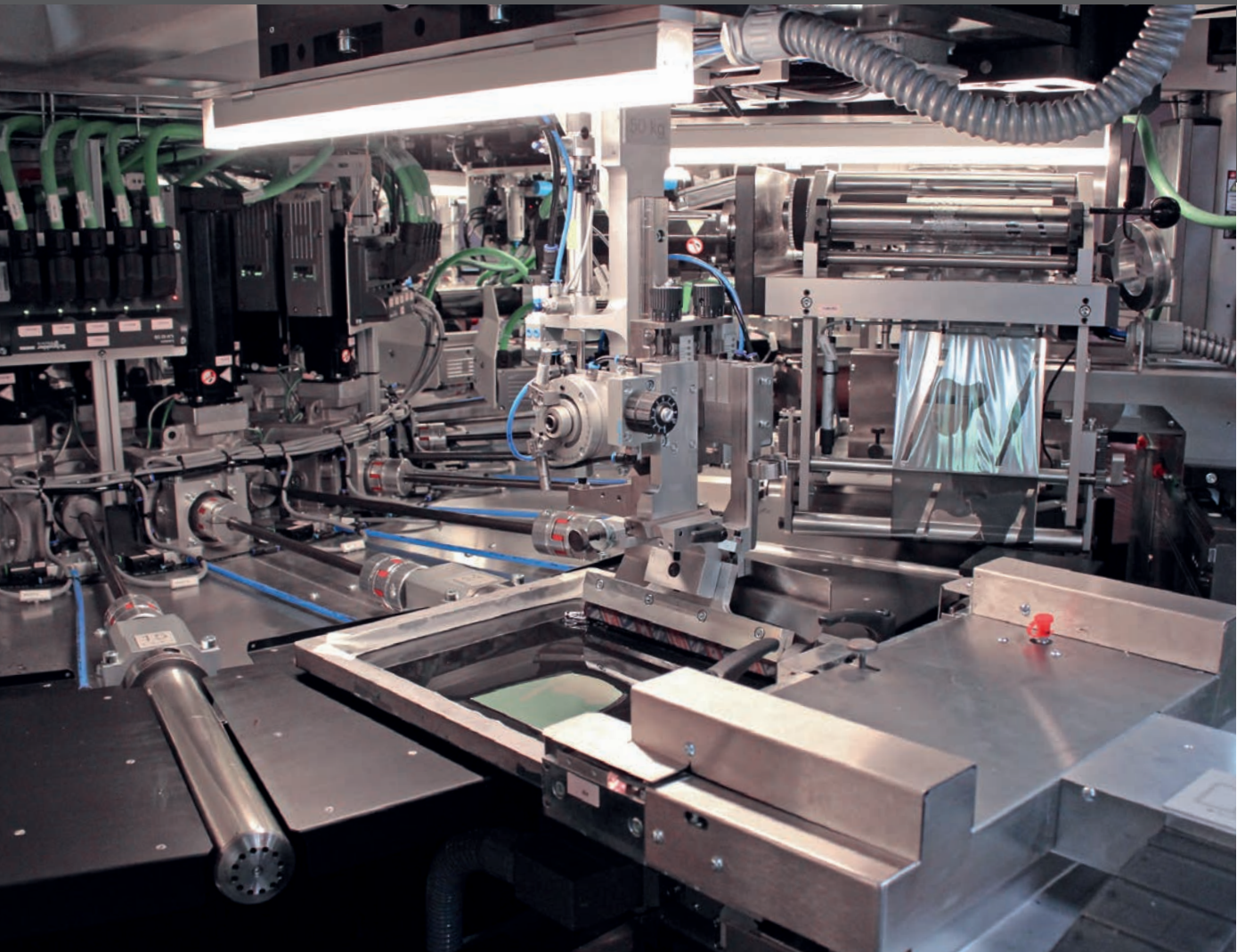

Your requirements are the benchmark for our printing machines when it comes to decorating tubes and sleeves. For our hybrid printing machines, we offer a wide range of printing technologies that can be individually combined or merged in a single press – as an inline or as a stand-alone solution. In addition, our machines are specially designed for direct printing and boast a mechanical circular ring on which the intake modules are mounted. Each intake is driven by a separate servo or torque motor. The tubes are accurately positioned on the mandrel of the respective printing station. The CNC control ensures the highest color-to-color register accuracy in multi-color printing.

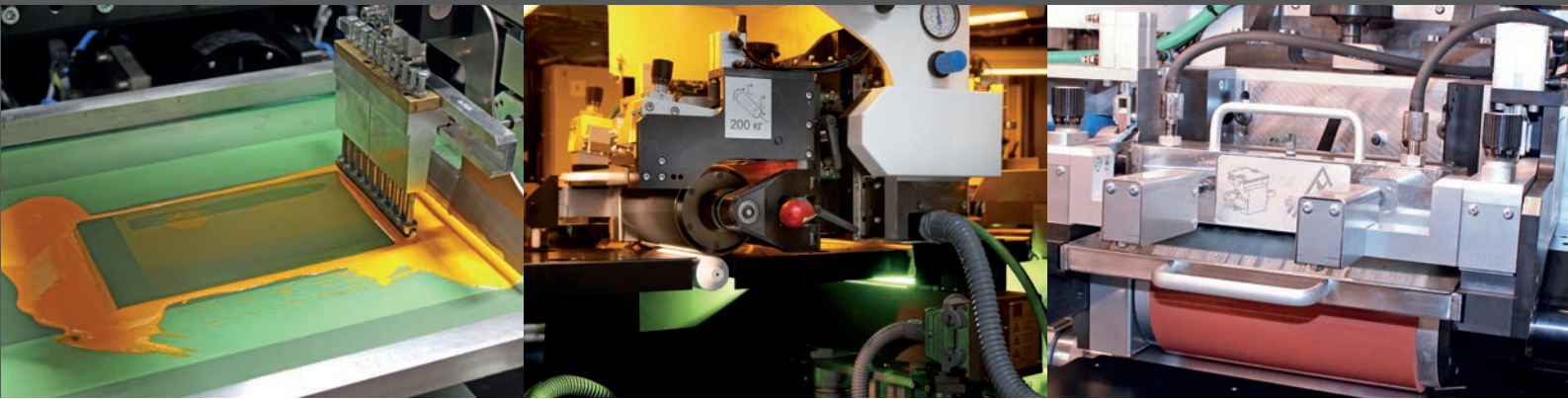

#### Screen printing printing unit:

We use flat screens for our T-series. These screens have a higher mesh count and have significant cost advantages over round screens. Pre-coated screens with a uniform emulsion thickness are also available.

#### Flexo printing unit:

The flexo printing unit developed by us have a special anilox roller that transfers ink from an ink chamber to the flexo plate on a plate roller. The flexo plate transfer the ink onto the tube in the flexo printing station.

#### Varnishing unit:

Our printing machines offer you the option of varnishing tubes in a flexo printing unit. This makes it possible to use both gloss and matt varnish on the tubes or sleeves.

#### Our screen printing units have the following properties:

- ✓ Screens controlled by servo motors
- ✓ High register accuracy during job changeovers
- ✓ Motor-controlled screen adjustment in increments of 0.01 mm (axial and radial)

#### Our flexo printing units have the following properties:

- ✓ DRP system (patented)
- ✓ Servo motor driven anilox roller and flexo plate roller
- ✓ Closed ink chamber with ink circulating between ink chamber and ink reservoir
- ✓ Quick-change sleeve as flexo plate roller
- ✓ Motor-controlled flexo plate roller adjustment in increments of 0.01 mm (axial and radial)

#### Our varnishing units have the following properties:

- ✓ Interchangeable varnishing unit
- ✓ Suitable for every station of the T-series



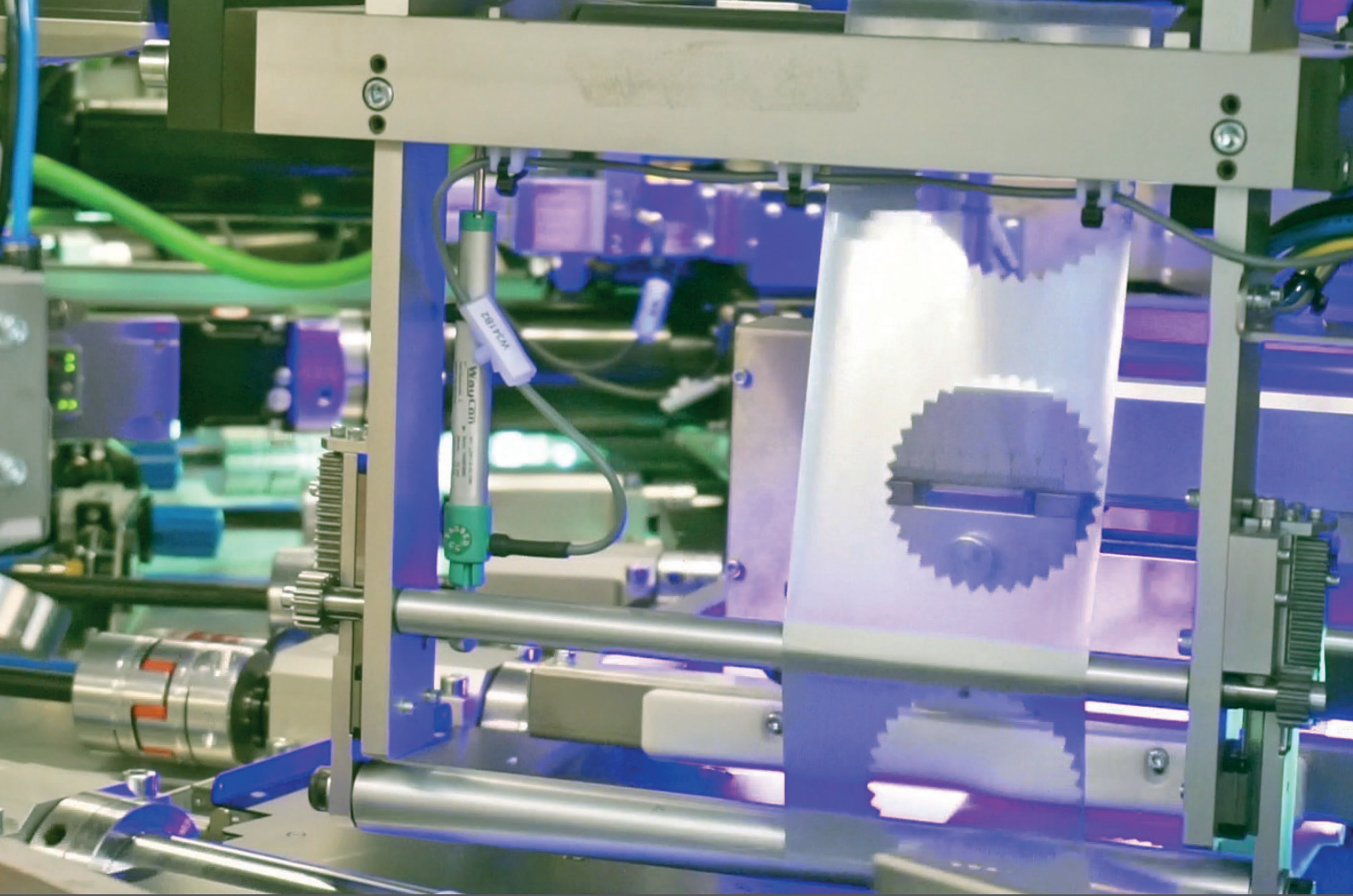

# inLINE FOILING® / DiF

Brilliant metallic eye-catchers  
on plastics







## Your advantages with inLINE FOILING® and DiF

- ✓ The silver foil can be over-varnished immediately with tinted varnish – offering countless color options for metallization
- ✓ Excellent edge definition
- ✓ High-gloss print motifs
- ✓ No additional product handling required – everything in a single pass at high speed
- ✓ 360° metallization possible with DiF

### Finish even delicate plastics without damage with high-gloss metallization – in just one pass

With the innovative inLINE FOILING® method, tubes and sleeves can be finished easily, quickly, and cost-effectively with extraordinary metallic decors – with little pressure and no heat.

inLINE FOILING® can be used in conjunction with flexo printing, screen printing, or digital printing in one machine pass. Owing to the perfect color-to-color registration, no further product handling is necessary.

#### It works like this:

- **A special adhesive is applied in screen printing**
- **Bringing the metallized layer of the foil into contact with the adhesive and curing the adhesive at the same time**
- **The metallization only sticks in the areas with the adhesive – the other areas remain unaffected**
- **The surface can now be over-varnished immediately to achieve a wide range of metallic effects**

### Even more flexible with Digital inLINE FOILING® (DiF)

For the first time, the new DiF process now makes it possible to apply 360° metallization to tubes and sleeves. This further development of the classic inLINE FOILING® method differs in that the special adhesive is not printed in advance via screen printing, but by means of digital printing technology directly in the transfer unit. This makes metallized all-round decorations possible. In addition, the ISIMAT T-series is made more flexible because the screen printing station is no longer needed for applying the adhesive.

# Benefit from the digital advantage

## High-efficiency tube finishing with Indirect Digital Decoration (IDD)

Flexibility, time, and cost – these are the three major factors that are increasingly deciding whether a project in your industry will be successful. Reason enough to include digital printing in your process portfolio in the future. In order to make today's and future tube decoration requirements even more flexible, we, as a leading tube printing provider, have thought out of the box and developed a highly efficient solution for our T-series for printing on tubes and sleeves: Indirect Digital Decoration (IDD). It combines the proven advantages of our high-performance printing presses with the benefits of digital printing.

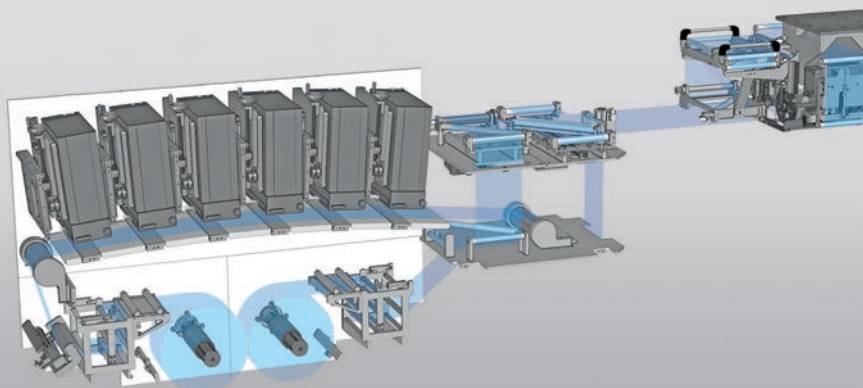

### Double the flexibility for tubes with more personality

With IDD, our new, indirect digital printing solution for the T-series high-performance tube printing machines, you are ahead of the competition in two ways when it comes to tube and sleeves finishing: You not only benefit from the efficiency benefits of the digital printing process itself. The technological principle of our modular ISIMAT solution for digital tube printing also offers advantages.

Our IDD module consists of two units. In the digital printing unit, a transfer foil is printed with the individual motif. The

second unit, the transfer module, is integrated into the machine. It ensures the transfer in register of the motif to the tube. The transferred print motif can, for example, be transferred to an already metallized print image. Synergies with other printing processes such as inLINE FOILING® or screen printing thus allow unprecedented finishing options.

IDD can be deployed as needed. If the project requires digital printing, IDD enables you to flexibly design your printing machine according to customer



requirements. For you, this means that – from large runs with changing print images through custom promotional series and personalized short runs to special editions with short production times – you're not only well-positioned with the printing technology for high-quality tube finishing, but you can also easily meet individual customer requirements across the board.

### Your benefits with IDD:

- ✓ Flexible digital printing solution for the T-series
- ✓ Ideal for personalization, serialization, customization
- ✓ Fast and cost-efficient processing of small and medium batch sizes
- ✓ Suitable for all tube diameters and print image lengths - no changeover necessary
- ✓ Brilliant designs with excellent gloss
- ✓ Finishing such as metallization via inLINE FOILING® or DiF possible
- ✓ Short setup and lead times and easy handling
- ✓ High process reliability thanks to already tested flat printing on the transfer foil



# Hybrid all-rounder

The TH 9 is a 9-color hybrid printing machine for multi-colored printing of plastic tubes and sleeves. It can be configured to print inline or stand-alone. As a high-performance tube printing machine, it ensures reliable 24/7 continuous operation. Extensive motorization and servo control ensure a very accurate color-to-color alignment during printing as well as short changeover times. The nine printing stations can be used independently of each other. Each station can hold a screen printing unit, a flexo printing unit, an inLINE FOILING® unit, an IDD transfer module, a DiF module, or a varnishing unit. The printing and decoration units can be combined as desired and arranged in any order.

## TH 9



### Technical data

Technical data	TH 9
Printing stations	9
Printing performance	up to 110 items/min.
Printed items	Tubes, sleeves
Diameter of printed items	25 – 56 mm *
Height of printed items	50 – 220 mm
Max. height of print image	200 mm
Colors	UV colors
Processing stations	24
Options	Sensor orientation, camera orientation, Corona surface treatment, Spot UV LED, inline print image control
<b>Decoration options</b>	
Screen printing	●
Flexo printing	●
Indirect Digital Decoration (IDD)	●
inLINE FOILING®	●
Digital inLINE FOILING® (DiF)	●
Varnishing	●

\* Other diameters on request

## Highly efficient thanks to two-up operation

The TD 7 is a high-performance tube printing machine with 7 screen printing stations for the inline printing of plastic tubes or sleeves. It is designed for reliable 24/7 operation and has a printing capacity of up to 200 items/min. Extensive motorization and a servo control system ensure a very accurate color-to-color registration during printing as well as short changeover times.



## All-rounder in continuous operation

The TS 6 is a screen printing machine with 6 printing stations – tried and tested in reliable 24/7 continuous operation. For printing plastic tubes and sleeves there is a choice between inline or stand-alone. Here, too, extensive motorization and a servo control system ensure a very accurate color-to-color registration during printing as well as short changeover times.



TD 7	TS 6
7	6
up to 200 items/min.	up to 110 items/min.
Tubes, sleeves	Tubes, sleeves
25 – 56 mm *	25 – 56 mm *
50 – 220 mm	50 – 220 mm
200 mm	200 mm
UV colors	UV colors
18	18
Sensor orientation, camera orientation, Corona surface treatment, color pumps, Spot UV LED, inline print image control	Sensor orientation, camera orientation, Corona surface treatment, color pumps, Spot UV LED, inline print image control
•	•
•	•
•	•
•	•
•	•

# Machinery and options

Innovation in detail for more efficiency in tube printing

As one of the world's leading manufacturers of tube printing machines, we are constantly working on new technologies that make our custom machines even better. We have registered several patents in Germany and worldwide and support our customers all the way from planning to production. Each of our machines is unique. And yet all have one thing in common: State-of-the-art technology down to the last detail – as standard or optional.





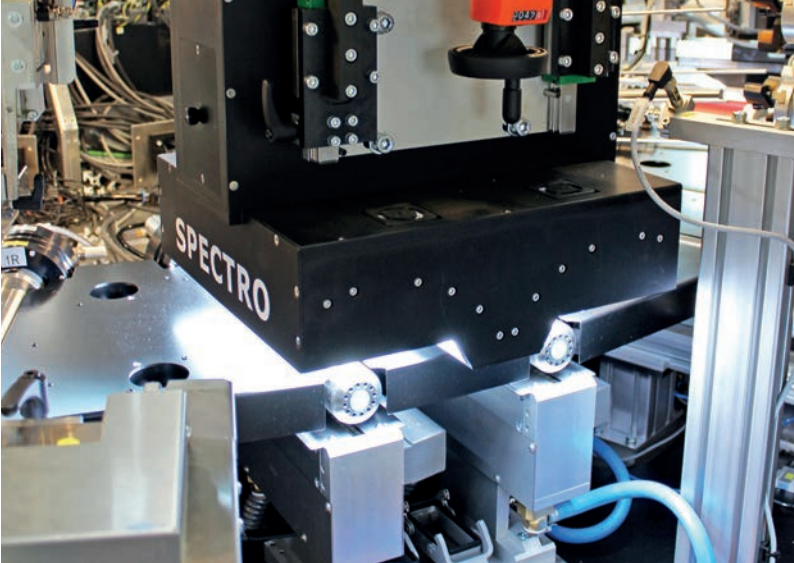

### Print inspection

There is the optional use of an integrated print image monitoring system. It is used in the last unloading station and ensures 100 % control over printing quality, even during production.

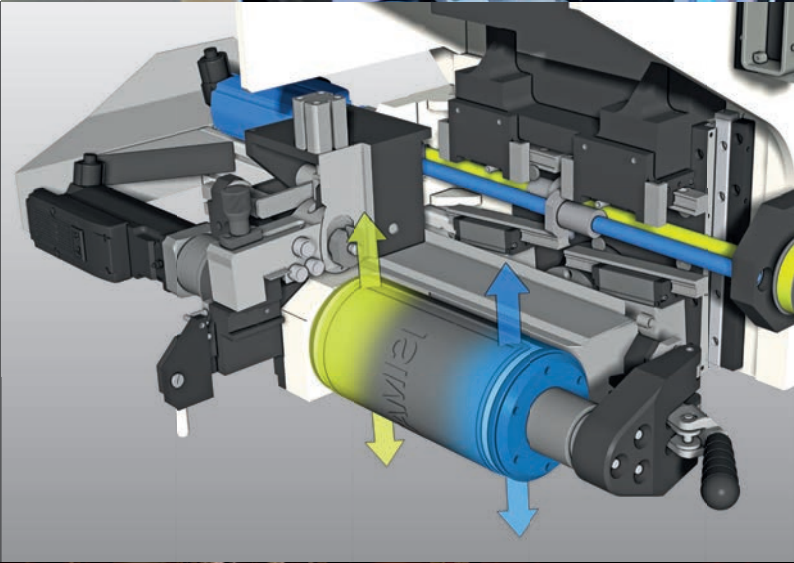

### Dynamic Roller Positioning (DRP)

The patented DRP system eliminates the mandrel impact on plastic tubes/sleeves, thus enabling high-quality flexo printing. Each mandrel has a minimal radial run-out. This can reduce or increase the distance to the flexo roll. In some areas the print image is no longer printed, in other areas the dots are squashed and the printed image appears smeared. The dynamic roller positioning (DRP) system moves the flexo unit of a flexo printing system so that the mandrel impact remains virtually ineffective.

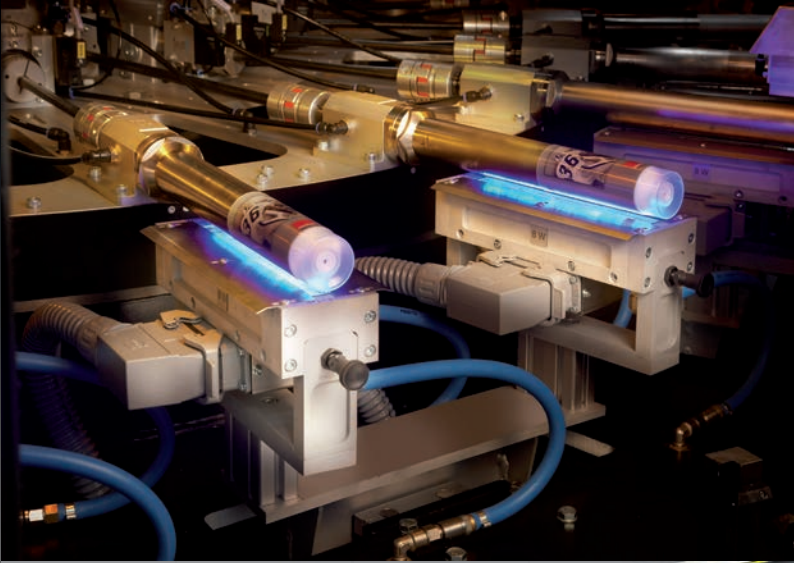

### Spot UV LED

The Spot UV LED enables seamless 360° wrap-arounds. It already dries the start of the printed area during the printing process. The print image can be up to 200 mm wide, creating an almost invisible combined print.

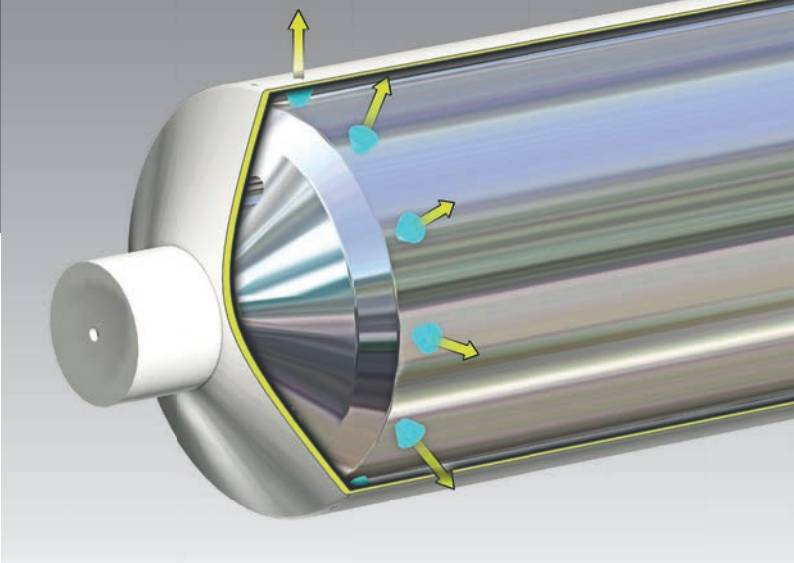

### Secure Hold (SH) mandrels

SH quick-change mandrels are used to compensate for tube tolerances. The outer diameter of the mandrels is about 0.2 mm larger than the upper tolerance limit of the inner tube diameter. When pushed together, an air cushion is created through a drill hole at the front end of the mandrel. This means the tubes are stretched and glide on an air cushion until the air pressure is switched off. As a result, the tubes are stretched tightly in place during the entire run through the machine.



We look forward to  
hearing from you!

## Contact:

**ISIMAT GmbH Siebdruckmaschinen**

Rindelbacher Str. 36-40  
73479 Ellwangen/Germany

+49 7961 / 886 0  
+49 7961 / 886 201  
info@isimat.de  
www.isimat.com

**Sales:**

+49 7961 / 886 0

**After Sales Service:**

+49 7961 / 886 699

The information provided herein is given with utmost care and according to our best knowledge and experience as of the date of this document, but NO REPRESENTATION, GUARANTEE OR WARRANTY, EXPRESSED OR IMPLIED IS MADE AS TO THE ACCURACY, RELIABILITY OR COMPLETENESS OF THE INFORMATION OR TO ANY SPECIAL QUALITY OR FITNESS OF THE MACHINE AND/OR FOIL FOR A SPECIAL APPLICATION. This information does not release the customer from his own liability for care examination, in particular with regard to the incoming goods inspection and any fitness of the respective machine and/or foil for his intended use. Execution of machine due to CE standards. inLINE FOILING® is a registered trademark of LEONHARD KURZ Stiftung & Co. KG. Issue 10/2019 - This document supersedes all previous issues.